

• General Description

The ZM075N03D combines advanced trench MOSFET technology with a low resistance package to provide extremely low $R_{DS(ON)}$. This device is ideal for load switch and battery protection applications.

• Features

- Advance high cell density Trench technology
- Low $R_{DS(ON)}$ to minimize conductive loss
- Low Gate Charge for fast switching
- Low Thermal resistance

• Application

- MB/VGA Vcore
- SMPS 2nd Synchronous Rectifier
- POL application
- BLDC Motor driver

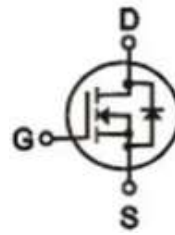
• Product Summary

$V_{DS} = 30V$

$R_{DS(ON)} = 7.5m\Omega$

$I_D = 55A$

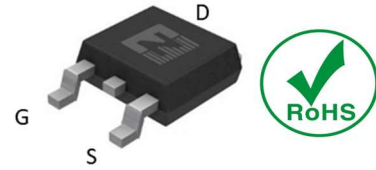

TO-252

• Ordering Information:

Part NO.	ZM075N03D
Marking	ZM075N03
Packing Information	REEL TAPE
Basic ordering unit (pcs)	2500

• Absolute Maximum Ratings (T_c =25°C)

Parameter	Symbol	Rating	Unit
Drain-Source Voltage	V_{DS}	30	V
Gate-Source Voltage	V_{GS}	±20	V
Continuous Drain Current	$I_{D@TC=25^{\circ}C}$	55	A
	$I_{D@TC=75^{\circ}C}$	42	A
	$I_{D@TC=100^{\circ}C}$	35	A
Pulsed Drain Current (Note 1)	I_{DM}	130	A
Total Power Dissipation(TC=25°C)	$P_D@TC=25^{\circ}C$	55	W
Total Power Dissipation(TA=25°C)	$P_D@TA=25^{\circ}C$	2	W
Operating Junction Temperature	T_J	-55 to 150	°C
Storage Temperature	T_{STG}	-55 to 150	°C
Single Pulse Avalanche Energy	E_{AS}	110	mJ

**•Thermal resistance**

Parameter	Symbol	Min.	Typ.	Max.	Unit
Thermal resistance, junction - case	R_{thJC}	-	-	2.3	$^{\circ}C/W$
Thermal resistance, junction - ambient	R_{thJA}	-	-	62.7	$^{\circ}C/W$
Soldering temperature, wavesoldering for 10s	T_{sold}	-	-	265	$^{\circ}C$

•Electronic Characteristics

Parameter	Symbol	Condition	Min.	Typ	Max.	Unit
Drain-Source Breakdown Voltage	BV_{DSS}	$V_{GS} = 0V, I_D = 250\mu A$	30			V
Gate Threshold Voltage	$V_{GS(TH)}$	$V_{GS} = V_{DS}, I_D = 250\mu A$	1.2		2.5	V
Drain-Source Leakage Current	I_{DSS}	$V_{DS} = 30V, V_{GS} = 0V$			1.0	μA
Gate- Source Leakage Current	I_{GSS}	$V_{GS} = \pm 20V, V_{DS} = 0V$			± 100	nA
Static Drain-source On Resistance	$R_{DS(ON)}$	$V_{GS} = 10V, I_D = 16A$		7.5	9.2	$m\Omega$
		$V_{GS} = 4.5V, I_D = 8A$		10.5	14	$m\Omega$
Forward Transconductance	g_{FS}	$V_{DS} = 25V, I_D = 10A$		5.4		S
Source-drain voltage	V_{SD}	$I_S = 16A$			1.28	V

•Electronic Characteristics

Parameter	Symbol	Condition	Min.	Typ	Max.	Unit
Input capacitance	C_{iss}	$V_{DS} = 25V$ $f = 1MHz$	-	1200	-	pF
Output capacitance	C_{oss}		-	235	-	
Reverse transfer capacitance	C_{rss}		-	120	-	

•Gate Charge characteristics($T_a = 25^{\circ}C$)

Parameter	Symbol	Condition	Min.	Typ	Max.	Unit
Gate Resistance	R_g	$f = 1MHz$		1.8		Ω
Total gate charge	Q_g	$V_{DD} = 15V$ $I_D = 16A$ $V_{GS} = 10V$	-	12	-	nC
Gate - Source charge	Q_{gs}		-	4	-	
Gate - Drain charge	Q_{gd}		-	6	-	
Turn-ON Delay time	$t_{D(on)}$	$V_{GS} = 10V, V_{DS} = 15V$		4.5		ns
Turn-ON Rise time	t_r	$R_G = 3.3\Omega, I_D = 15A$		12		ns

Turn-Off Delay time	$t_{D(off)}$		26	ns
Turn-Off Fall time	t_f		7.5	ns

Note: ① Pulse Test : Pulse width $\leq 300\mu s$, Duty cycle $\leq 2\%$;

Fig.1 Power Dissipation

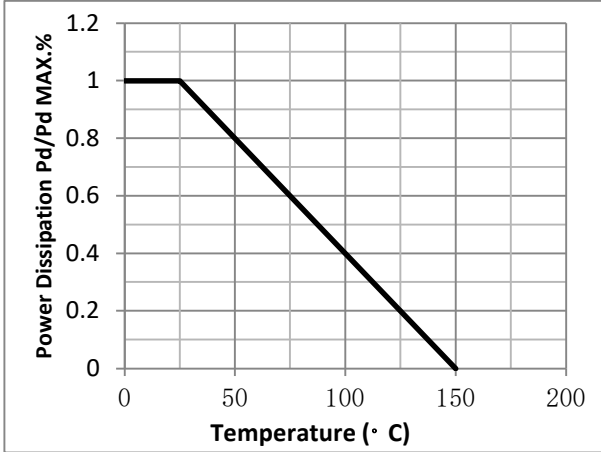

Fig.2 Typical output Characteristics

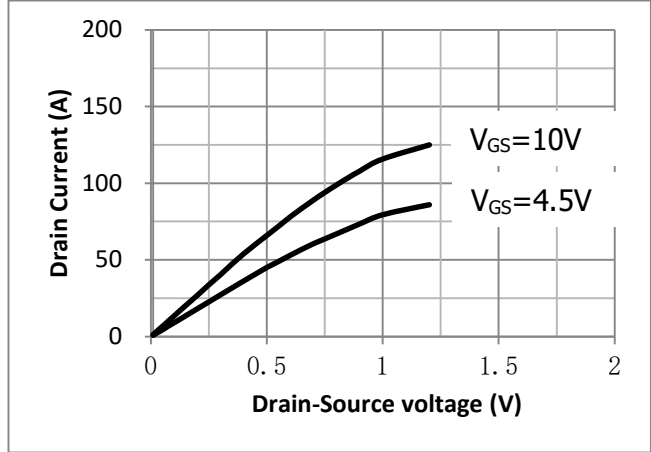

Fig.3 Threshold Voltage V.S Junction Temperature

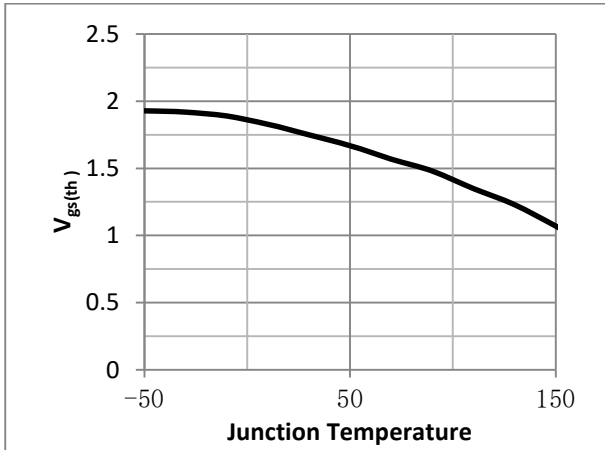

Fig.4 Resistance V.S Drain Current

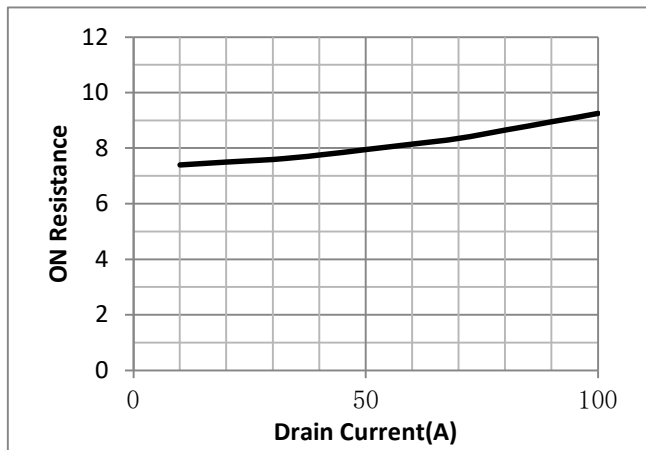

Fig.5 On-Resistance VS Gate Source Voltage

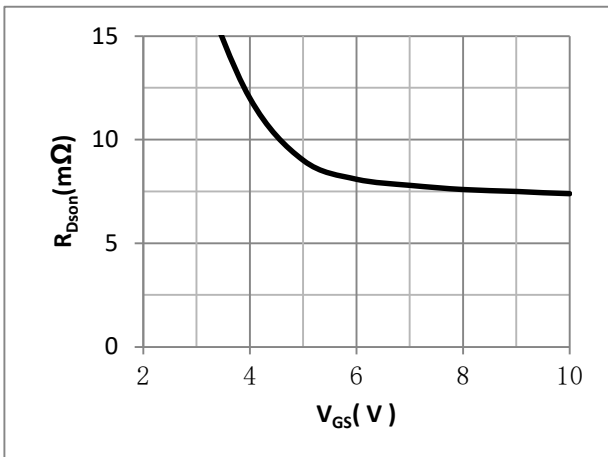

Fig.6 On-Resistance V.S Junction Temperature

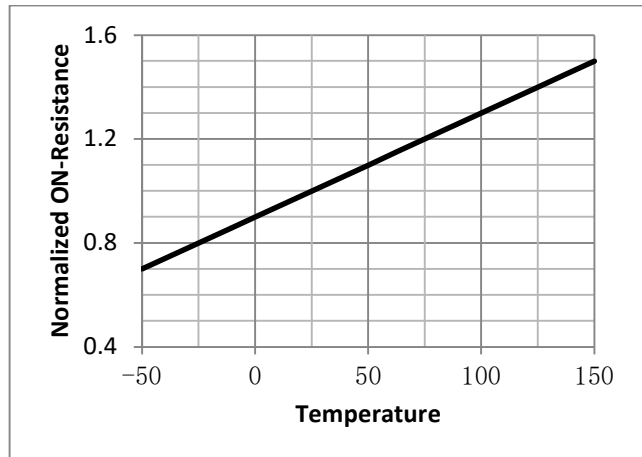

Fig.7 Gate Charge Measurement Circuit

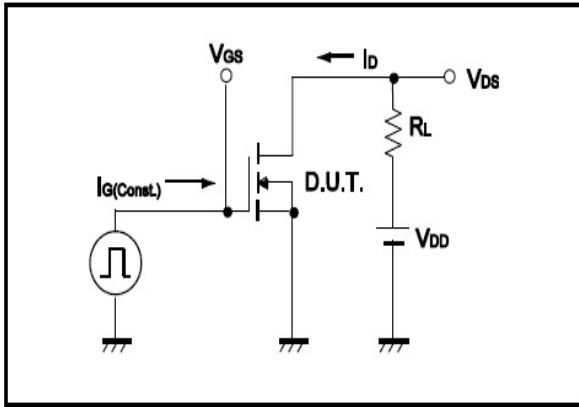

Fig.8 Gate Charge Waveform

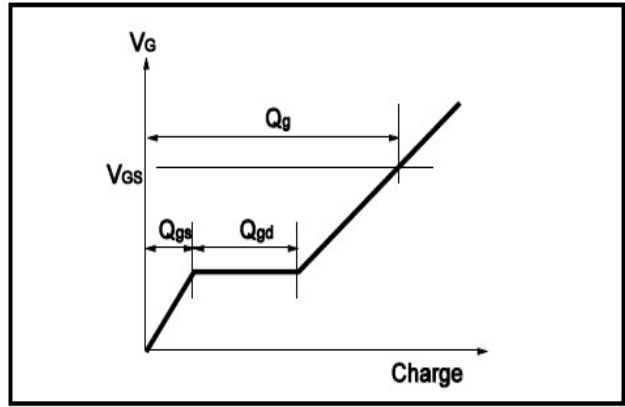

Fig.9 Switching Time Measurement Circuit

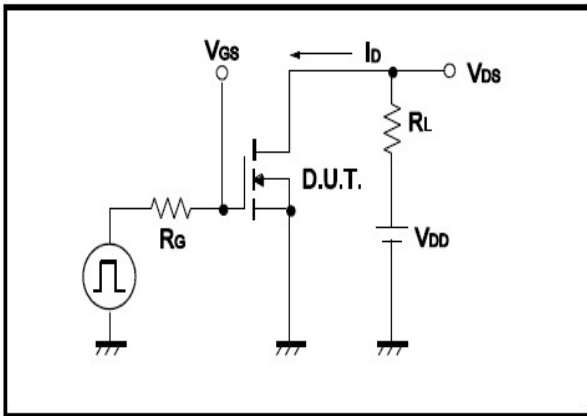

Fig.10 Switching Time Waveform

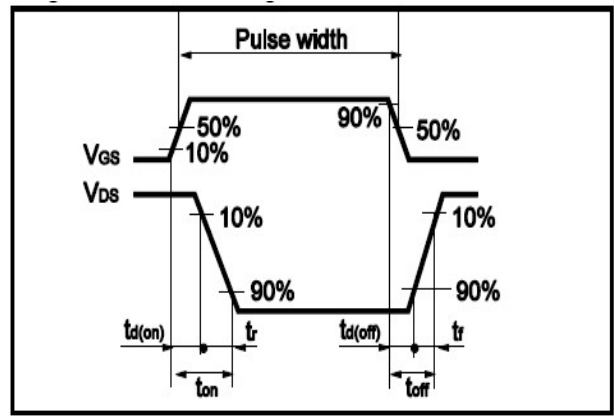

Fig.11 Avalanche Measurement Circuit

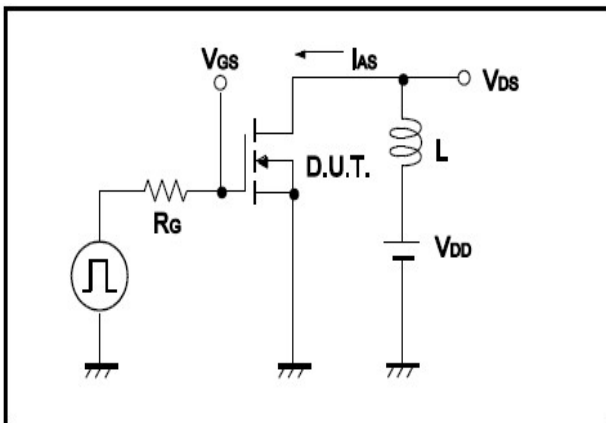
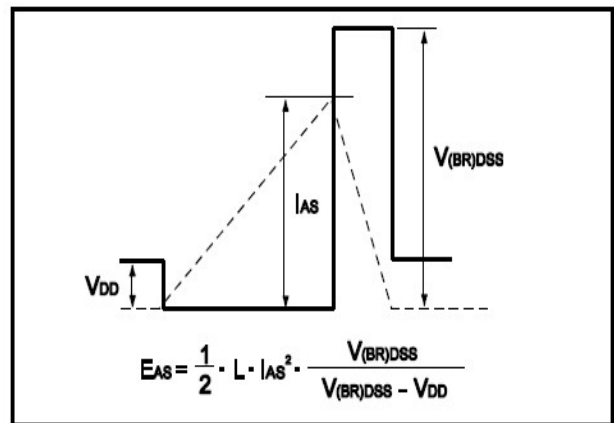

Fig.12 Avalanche Waveform





•Dimensions(TO-252)

Unit: mm

SYMBOL	min	max	SYMBOL	min	max
A	2.10	2.50	B	0.85	1.25
b	0.50	0.80	b1	0.50	0.90
b2	0.45	0.70	C	0.45	0.70
D	6.30	6.75	D1	5.10	5.50
E	5.30	6.30	e1	2.25	2.35
L1	9.20	10.60	e2	4.45	4.75
L2	0.90	1.75	L3	0.60	1.10
K	0.00	0.23			

